



C-TWYN-EC

Twin screw feeding unit - Easy cleaning system

C-TWYN-EC is a twin screw feeding unit engineered in different sizes in order to feed powders, granules, pellets, flakes and fibers and is available in volumetric or gravimetric versions. In the loss-in-weight modules, an analogue load cell is installed to guarantee a high weighing accuracy.

The EC Series is ideal for versatile production lines where a fast and accurate cleaning of the feeder is required.



PRINCIPLE OF OPERATION

One single motor through an integrated gear box, or 2 independent motors, drives the feeding screw and the horizontal agitator which avoids bridging and keeps a constant material flow. Different screw configurations allows the user to feed any kind of product with any kind of throughput accurately and with consistency.

MAIN FEATURES

EASY AND FAST CLEANING

Both the front and back feeder covers can be completely disassembled, the back part is held by a rail, ensuring an easy and fast cleaning operations

HIGH PERFORMANCE

C-TWYN-EC can guarantee a high accuracy in feeding (+/- 0.5%) in a range of 1:20.

WIDE RANGE OF MODELS

The wide range of different dosing units allows the user to feed from 0,2 to 10.800 dm³/h.

MODULAR DESIGN

The design allows the possibility to change material and feed-rate by simply changing the screw and discharge outlet.

MODULAR HOPPERS

Various shapes and sizes of standard hoppers can be perfectly combined with various measuring extensions chosen in relation to flow rate, in order to meet different dosing needs. Analog load cell features.

WEIGHING SYSTEM

C-TWYN-EC gravimetric units can be installed on a platform scale or in a special designed scale frame to keep the equipment more compact.

INSTALLATIONS

C-TWYN-EC is always supplied prewired with junction boxes to permit an easy and fast installation.

C-TWYN-EC feeders can be installed in a standalone frame or in a modular multi component dosing station frame C-MULTY which is available in various configurations: DS-4, DS-6 and DS-8, from 2 to 8 feeding units.

CONTROL SYSTEM & INDUSTRY 4.0

Feeder control system can manage from a single feeder up to several feeders and production lines. The PLC is supplied with OPC/UA protocol embedded, which make each machine modular and ready for industry 4.0.

HMI

The feeding control system is equipped with a user friendly HMI touch screen (7"-9"-15").

OPTIONS AVAILABLE

As an option, C-TWYN-EC can be equipped with a vertical agitator, designed for high temperatures, ATEX compliant and/or FDA compliant.

TECHNICAL DATA

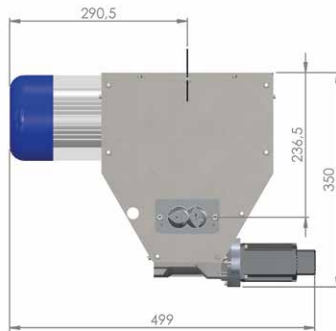
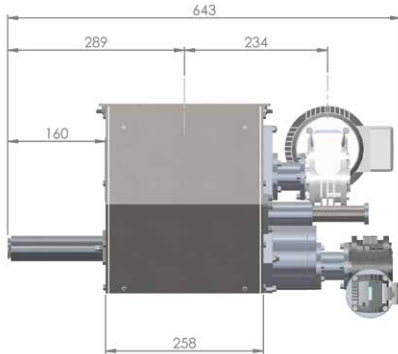

Configuration

- Cylindrical Hopper 28 lt
- Asymmetric Hopper 60 lt
- Asymmetric Hopper 90 lt
- Hopper extension 25/50/100 lt
- Stand alone feeder
- Multi feeder C-MULTY

Configuration

- AC motor
- Brushless motor
- Single motorization
- Double motorization
- FDA compliant
- ATEX compliant

Technical Data

Brushless Motor - Drive

- Motor Size 0.4 kW
- Voltage 230 V
- Motor Class IP55
- Speed Reducers 7:1 / 14:1 / 30:1

Option

- Vertical Agitator for conical, asymmetric Hoppers
- Screw extension 50 mm
- Horizontal agitator for powder
- Horizontal agitator for flakes or granules
- Horizontal agitator for fiber

AC Motor - Drive (Option)

- Motor Size 0.37 kW
- Voltage 230-460/3/50-60Hz
- Motor Class IP55
- Speed Reducers 7:1 / 14:1 / 30:1

C-TWYN EC20

Gear (Brushless motor)	rpm (screw)	CONCAVE		AUGER	SPIRAL
		Φ 22 x 11	Φ 22 x 20	Φ 20 x 20	Φ 20 x 20
		dmc/h	dmc/h	dmc/h	dmc/h
30:1	4,6 - 93	0,6 - 12	1 - 21	1,4 - 28	1,8 - 37
14:1	10 - 200	1,3 - 26	2,3 - 46	3 - 60	4 - 80
7:1	20 - 400	2,6 - 52	4,6 - 92	6 - 120	8 - 160
Gear (AC motor)	rpm (screw)	Φ 22 x 11	Φ 22 x 20	Φ 20 x 20	Φ 20 x 20
		dmc/h	dmc/h	dmc/h	dmc/h
30:1	18 - 86	2,3 - 12	4 - 20	5,4 - 25,8	7,2 - 34,4
14:1	40 - 185	5 - 24	9 - 42	12 - 55	16 - 74
7:1	80 - 370	10 - 48	18 - 84	24 - 110	32 - 148

C-TWYN-EC28

Gear (Brushless motor)	rpm (screw)	CONCAVE			AUGER	SPIRAL	
		Φ 32 x 30	Φ 35 x 40	Φ 35 x 50	Φ 32 x 30	Φ 30 x 16	Φ 30 x 30
		dmc/h	dmc/h	dmc/h	dmc/h	dmc/h	dmc/h
30:1	4,6 - 93	8,6 - 174	18 - 362	22 - 446	9,7 - 195	2,8 - 56	6 - 120
14:1	10 - 200	18,7 - 374	29 - 780	48 - 960	21 - 420	6 - 120	13 - 260
7:1	20 - 400	37,4 - 748	78 - 1560	96 - 1920	42 - 840	12 - 240	26 - 520
Gear (AC motor)	rpm (screw)	Φ 32 x 30	Φ 35 x 40	Φ 35 x 50	Φ 32 x 30	Φ 30 x 16	Φ 30 x 30
		dmc/h	dmc/h	dmc/h	dmc/h	dmc/h	dmc/h
30:1	18 - 86	34 - 160	70 - 335	86 - 412	38 - 180	11 - 52	23 - 111
14:1	40 - 185	75 - 345	156 - 721	192 - 888	84 - 388	24 - 111	52 - 240
7:1	80 - 370	150 - 690	312 - 1443	384 - 1776	168 - 777	48 - 222	104 - 480

C-TWYN-EC35

Gear (Brushless motor)	rpm (screw)	CONCAVE		AUGER	SPIRAL	
		Φ 38 x 35	Φ 42 x 40	Φ 42 x 40	Φ 44 x 20	Φ 44 x 40
		dmc/h	dmc/h	dmc/h	dmc/h	dmc/h
30:1	4,6 - 93	12,3 - 246	22,3 - 446,4	22,5 - 450	7,6 - 151	16,2-324
14:1	10 - 200	26,7 - 535	36 - 719,3	48,7 - 974,4	16,2 - 324	35-702
7:1	20 - 400	53,5 - 1070	96,7 - 1934,4	97,5 - 1949	32,4 - 648	70-1404
Gear (AC motor)	rpm (screw)	Φ 38 x 35	Φ 42 x 40	Φ 42 x 40	Φ 30 x 16	Φ 30 x 30
		dmc/h	dmc/h	dmc/h	dmc/h	dmc/h
30:1	18 - 86	48,6 - 229	86,8 - 408	88 - 414,4	29,7 - 139,6	29,7-139,6
14:1	40 - 185	107,2 - 504	193,4 - 909	195 - 916	64,8 - 304,5	65-304,6
7:1	80 - 370	214,5 - 1008	386,9 - 1818,4	390 - 1832	129,6 - 609	130-609